

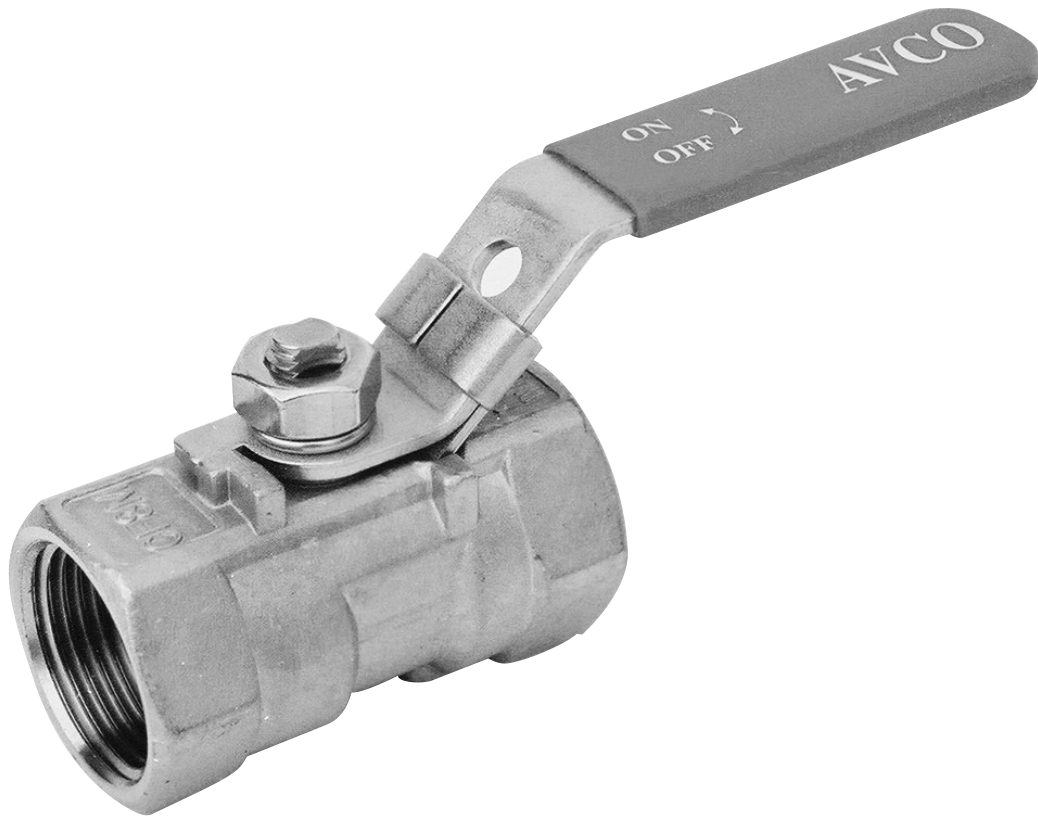

*Alloy Valves and Control*

# BALL VALVES 100 SERIES



**Size:**

1/4" - 2" Reduce Port  
800 WOG

**End Connections:**

NPT

**Valve Materials**

316 Stainless Steel

**Ball and Stem Materials:**

316 Stainless Steel

**Service Applications:**

Hydraulic	Chemical
Steam	Oil/Gas
Oxygen	Food Processing
Vacuum	

**Seat Materials:**

Teflon

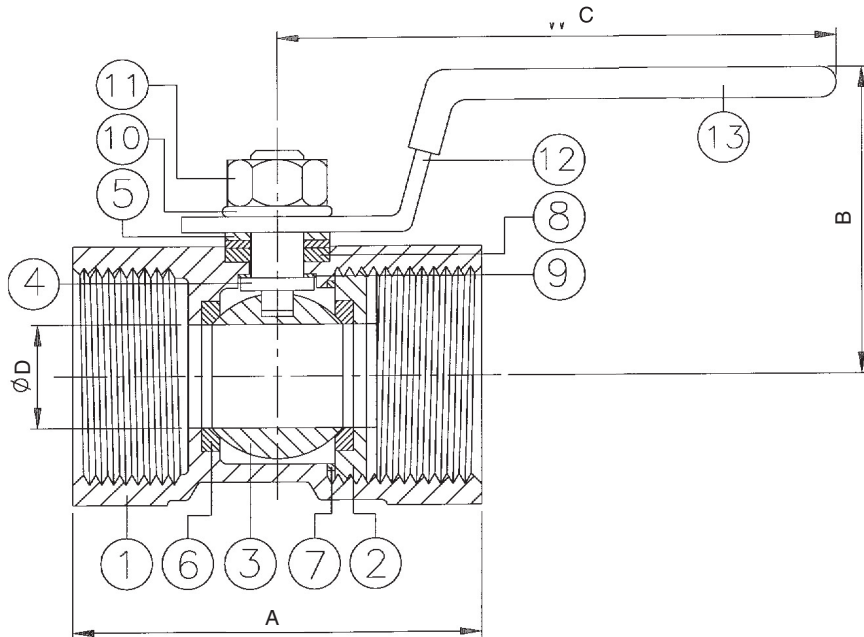

### Features

The thread ends conform to ASME B1.20.1(NPT)  
 Investment Casting  
 Blow-out proof stem  
 Reduce bore 800 W.O.G.  
 TFE Seat  
 PTFE seal & packing

	Parts	Material
1	Body	ASTM A351-CF8M
2	Retainer	ASTM A351-CF8M
3	Ball	ASTM A351-CF8M
4	Stem	ASTM A351-CF8M
5	Gland Ring	AISI 304
6	Ball Seat	TFE
7	Body Seal	PTFE
8	Packing	PTFE
9	Thrust Washer	PTFE
10	Spring Washer	AISI 304
11	Stem Nut	AISI 304
12	Handle	AISI 304
13	Handle Sleeve	PVC

SIZE	A	B	C	D	WEIGHT/LB	TORQUE IN/LB	CV
1/4"	1.56	1.40	2.38	0.20	0.18	3.5	2.5
3/8"	1.76	1.48	2.80	0.28	0.24	7.0	4.5
1/2"	2.26	1.74	3.60	0.36	0.44	11.20	7
3/4"	2.32	1.88	3.60	0.50	0.70	19.00	9
1"	2.84	2.00	4.12	0.64	0.99	30.10	16
1-1/4"	3.12	2.28	4.12	0.80	1.70	44.10	24
1-1/2"	3.32	2.76	5.08	0.98	2.18	56.60	37
2"	4.00	2.98	5.08	1.28	3.55	91.20	68

### HOW TO ORDER

1"	1	3	3	T	T	SE
Size	Series	Body & End Material	Ball & Stem	Seat	Seal	End
1/4" 3/8" 1/2" 3/4" 1" 1 1/4" 1 1/2" 2"	100 Series 1 Piece Ball Valve	3-316SS	3-316SS	T-Teflon	T-Teflon	SE-FNPT

Distributed by: