

Alloy Valves and Control

### RING TYPE JOINT HOLDERS

#### INTEGRAL TYPE

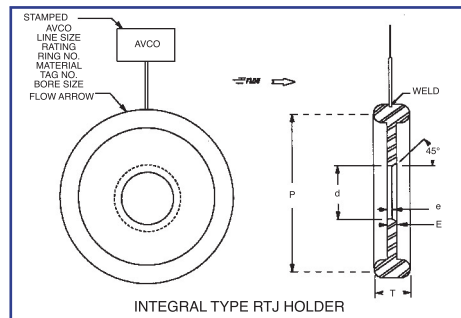

INTEGRAL TYPE RTJ HOLDER

The Integral Type, is an oval type orifice plate which is the most commonly manufactured RTJ holder. The one piece design provides the greatest durability.

#### SCREW TYPE

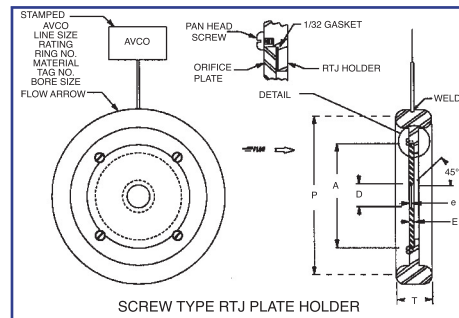

SCREW TYPE RTJ PLATE HOLDER

The Screw Type, is an oval type RTJ holder which is the second most commonly manufactured RTJ holder. The 1/32" thick gasket presents a possibility of differential leakage. If accidentally installed backwards, the orifice plate could be dislodged downstream.

#### SNAP RING TYPE

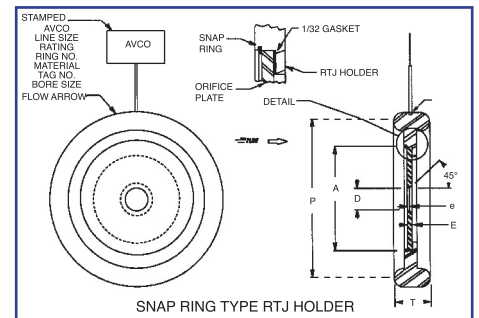

SNAP RING TYPE RTJ HOLDER

The Snap Ring Type is the least popular design. The gasket creates a possibility of differential pressure leakage.

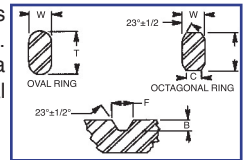

#### 300/600 #ANSI RATING

LINE SIZE INCHES	RING NO.	RING DIMENSIONS					ORIFICE PLATE DIMENSIONS			GROOVE DIMENSIONS		DISTANCE BETWEEN FLANGES
		T	B	W	C	P	A	E	e	F	D	
1/2	R 11	29/32	31/32	1/4	0.170	1-11/32	*	1/8	1/32	9/32	7/32	19/32
3/4	R 13	1	1-1/16	5/16	0.206	1-11/16	*	1/8	1/32	11/32	1/4	19/32
1	R 16	1	1-1/16	5/16	0.206	2	*	1/8	1/32	11/32	1/4	19/32
1-1/2	R 20	1	1-1/16	5/16	0.206	2-11/16	*	1/8	1/32	11/32	1/4	19/32
2	R 23	1-1/16	1-1/8	7/16	0.305	3-1/4	2.437	1/8	1/32	15/32	5/16	5/8
3	R 31	1-1/16	1-1/8	7/16	0.305	4-7/8	3.437	1/8	1/32	15/32	5/16	5/8
4	R 37	1-1/16	1-1/8	7/16	0.305	5-7/8	4.406	1/8	1/16	15/32	5/16	5/8
6	R 45	1-1/16	1-1/8	7/16	0.305	8-5/16	6.437	1/8	1/16	15/32	5/16	5/8
8	R 49	1-1/16	1-1/8	7/16	0.305	10-5/8	8.437	1/8	1/8	15/32	5/16	5/8
10	R 53	1-1/16	1-1/8	7/16	0.305	12-3/4	10.687	1/8	1/8	15/32	5/16	5/8
12	R 57	1-1/16	1-1/8	7/16	0.305	15	12.593	1/4	1/8	15/32	5/16	5/8
14	R 61	1-1/16	1-1/8	7/16	0.305	16-1/2	14.000	1/4	1/8	15/32	5/16	5/8
16	R 65	1-3/16	1-1/4	7/16	0.305	18-1/2	16.000	1/4	1/4	15/32	5/16	3/4
18	R 69	1-3/16	1-1/4	7/16	0.305	21	18.000	1/4	1/4	15/32	5/16	3/4
20	R 73	1-1/4	1-5/16	1/2	0.341	23	20.000	3/8	1/4	17/32	3/8	3/4
24	R 77	1-7/16	1-1/2	5/8	0.413	27-1/4	24.000	3/8	1/4	21/32	7/16	13/16

#### 900 #ANSI RATING

LINE SIZE INCHES	RING NO.	RING DIMENSIONS					ORIFICE PLATE DIMENSIONS			GROOVE DIMENSIONS		DISTANCE BETWEEN FLANGES
		T	B	W	C	P	A	E	e	F	D	
1/2	R 12	1	1-1/16	5/16	0.206	1-9/16	*	1/8	1/32	11/32	1/4	19/32
3/4	R 14	1	1-1/16	5/16	0.206	1-3/4	*	1/8	1/32	11/32	1/4	19/32
1	R 16	1	1-1/16	5/16	0.206	2	*	1/8	1/32	11/32	1/4	19/32
1-1/2	R 20	1	1-1/16	5/16	0.206	2-11/16	*	1/8	1/32	11/32	1/4	19/32
2	R 24	1-1/16	1-1/8	7/16	0.305	3-3/4	2.437	1/8	1/32	15/32	5/16	5/8
3	R 31	1-1/16	1-1/8	7/16	0.305	4-7/8	3.437	1/8	1/32	15/32	5/16	5/8
4	R 37	1-1/16	1-1/8	7/16	0.305	5-7/8	4.406	1/8	1/16	15/32	5/16	5/8
6	R 45	1-1/16	1-1/8	7/16	0.305	8-5/16	6.437	1/8	1/16	17/32	3/8	5/8
8	R 49	1-1/16	1-1/8	7/16	0.305	10-5/8	8.437	1/8	1/8	21/32	7/16	5/8
10	R 53	1-1/16	1-1/8	7/16	0.305	12-3/4	10.687	1/8	1/8	21/32	7/16	5/8
12	R 57	1-1/16	1-1/8	7/16	0.305	15	12.593	1/4	1/8	29/32	9/16	5/8
14	R 62	1-5/16	1-3/8	5/8	0.413	16-1/2	14.000	1/4	1/8	1-1/16	5/8	11/16
16	R 66	1-7/16	1-1/2	5/8	0.413	18-1/2	16.000	1/4	1/4	1-3/16	11/16	13/16
18	R 70	1-9/16	1-5/8	3/4	0.484	21	18.000	1/4	1/4	1-3/16	11/16	15/16
20	R 74	1-9/16	1-5/8	3/4	0.485	23	20.000	3/8	1/4	1-5/16	11/16	15/16
24	R 78	1-7/8	1-15/16	1	0.681	27-1/4	24.000	3/8	1/4	1-7/16	13/16	15/16

\* = INTEGRAL TYPE ONLY